

## **X-Axis Motor Replacement**

Fusion Edge 12, 24, 36 & Fusion Pro 24, 36

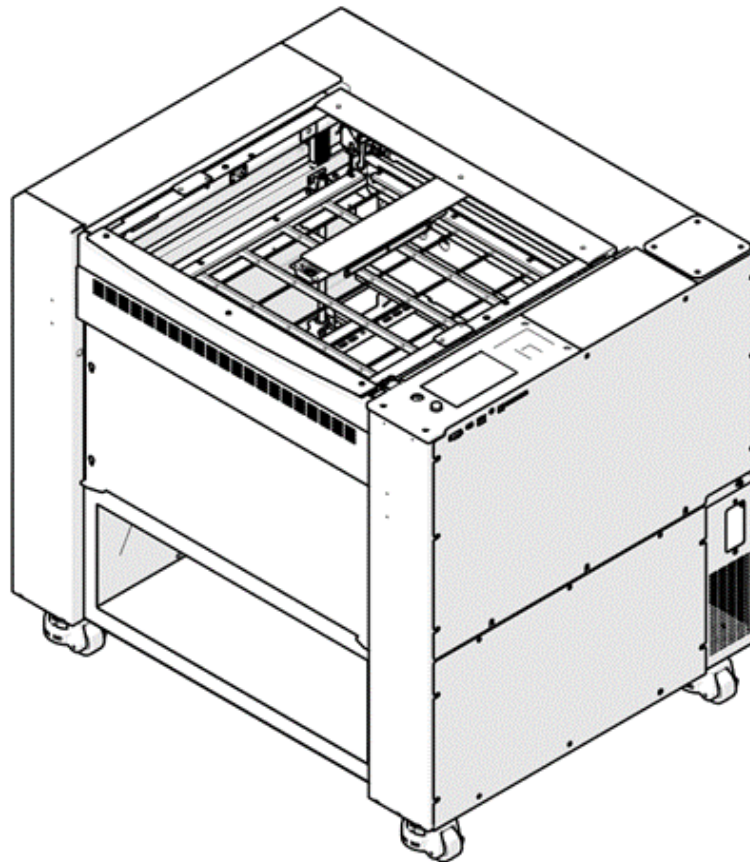

**Tools Required**

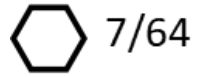
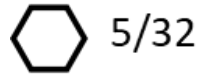

**X Axis Motor Removal**

1. Turn off the engraver.



2. Disconnect the power.



# Edge/Edge Pro X-Axis Motor

3. Remove:

5/32

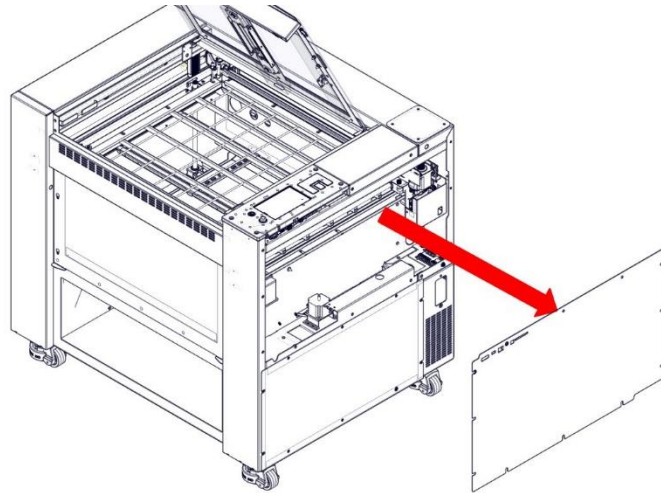

4. Move:

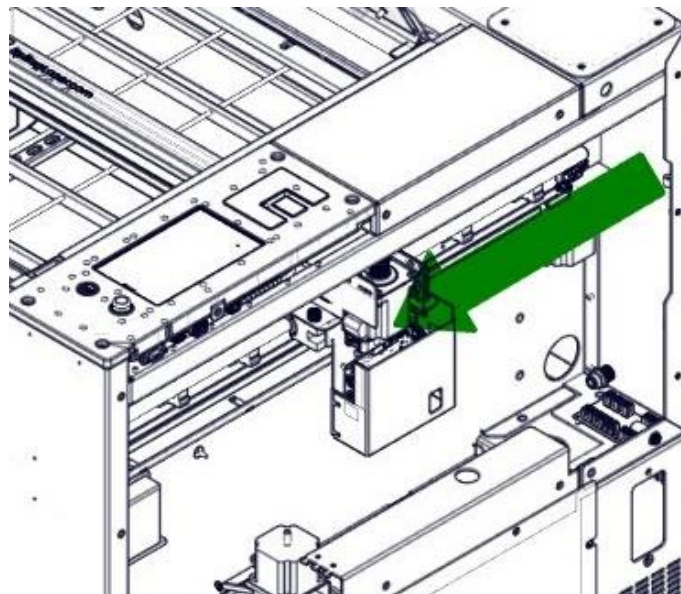

# Edge/Edge Pro X-Axis Motor

5. Loosen:

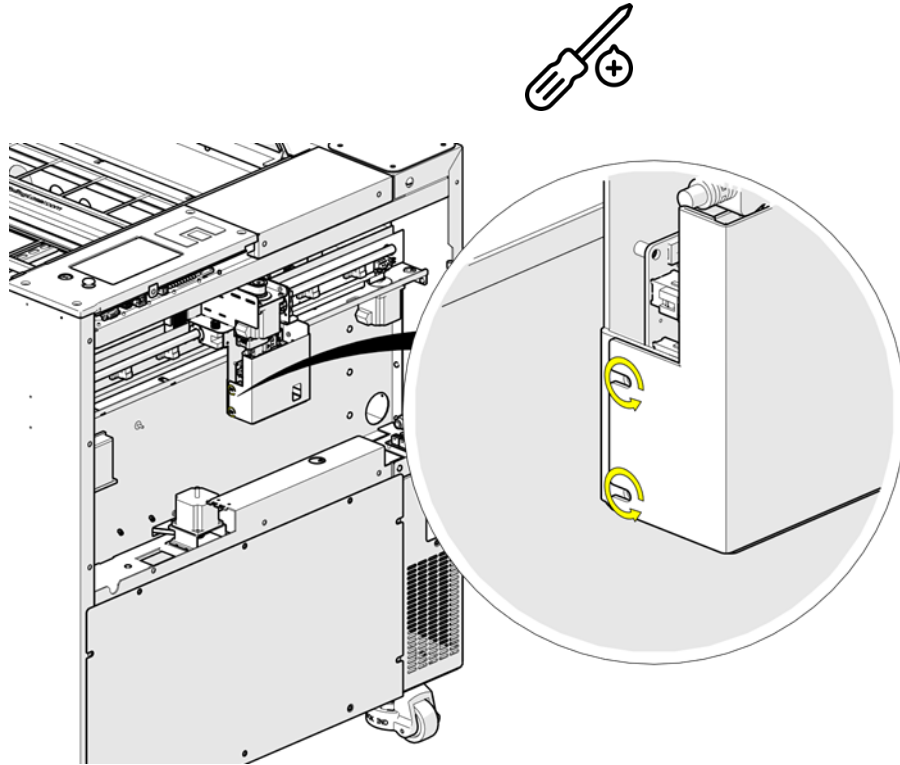

6. Loosen:

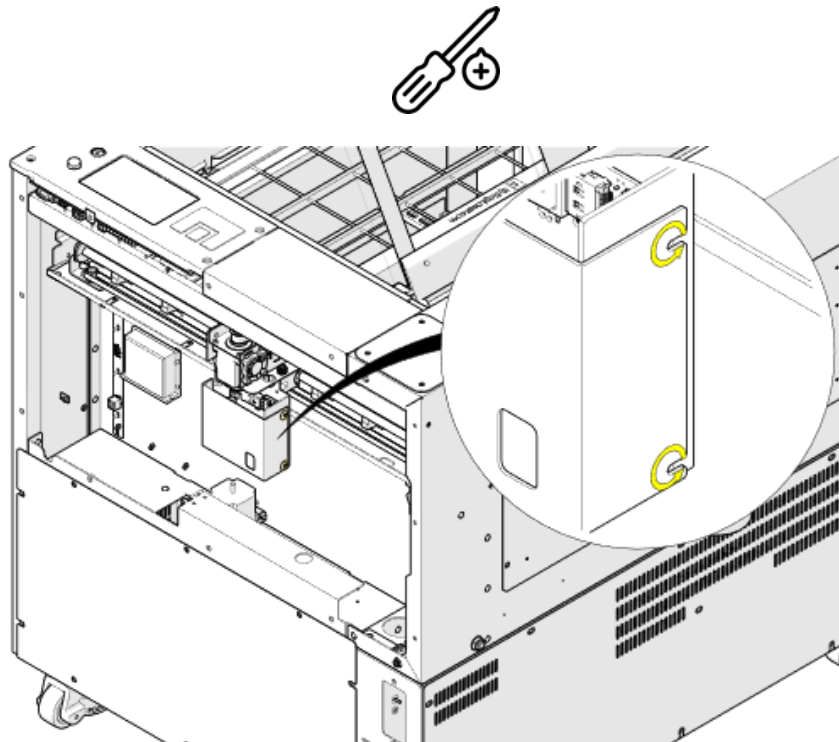

7. Remove:

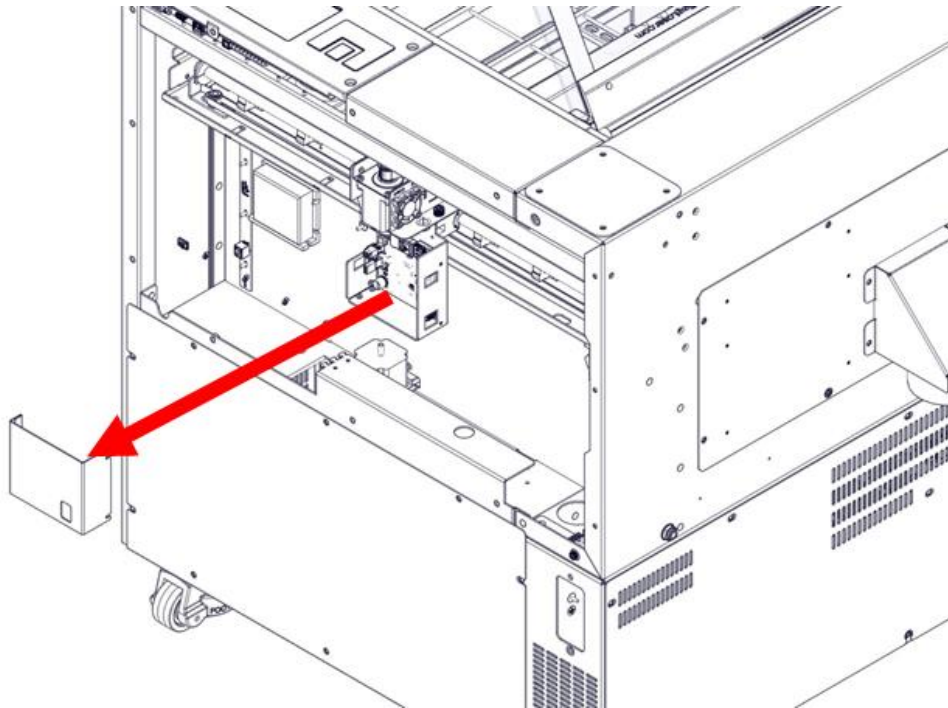

8. Disconnect

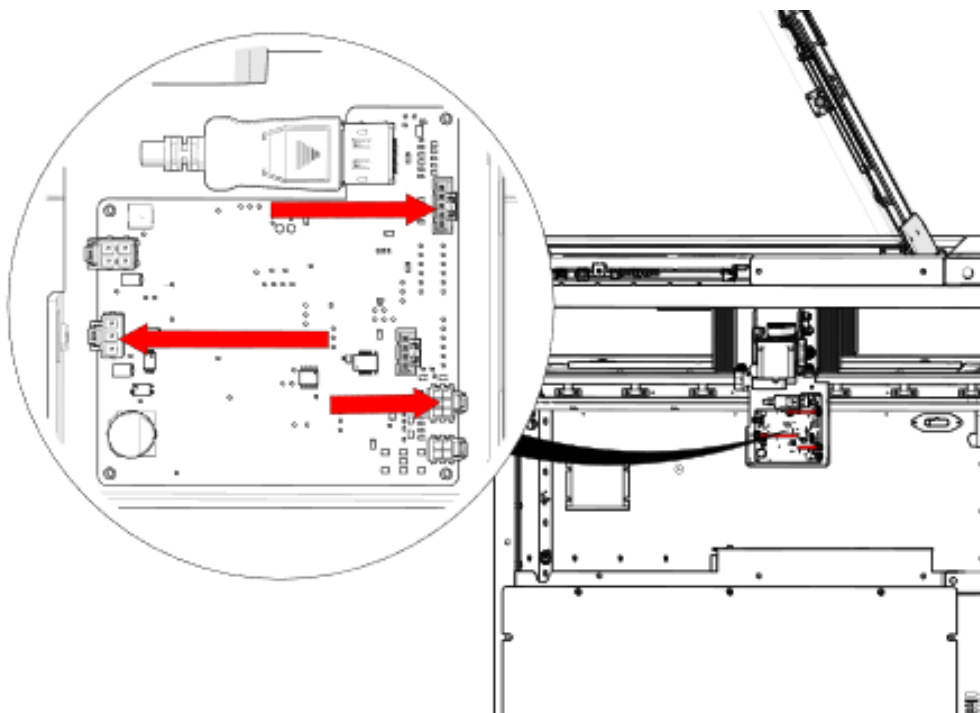

9. Loosen:

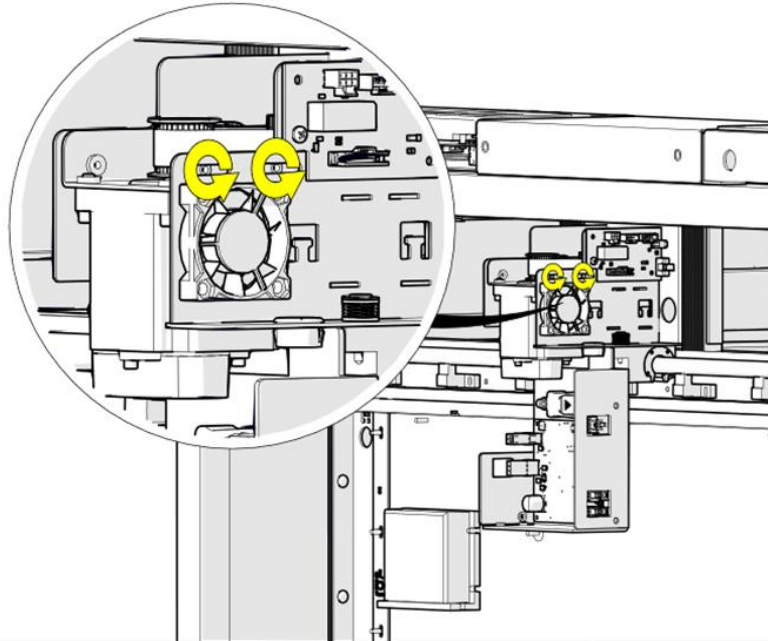
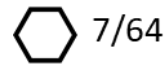

10. Loosen:

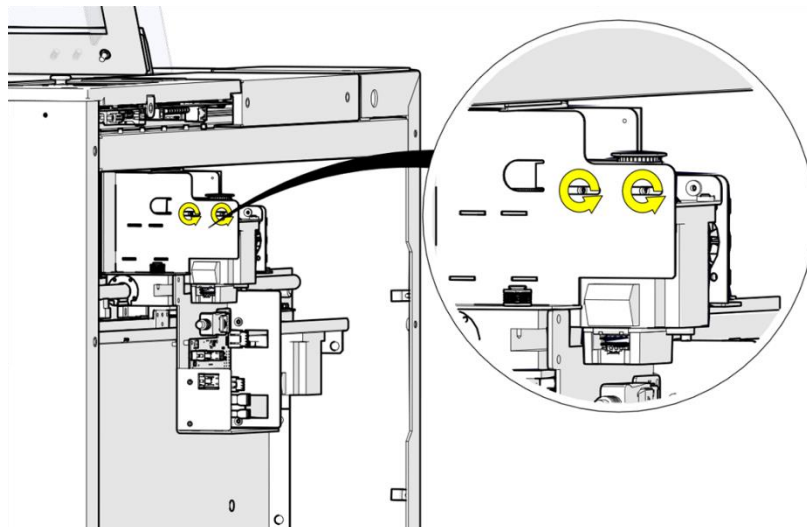
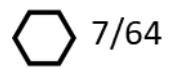

11. Loosen:

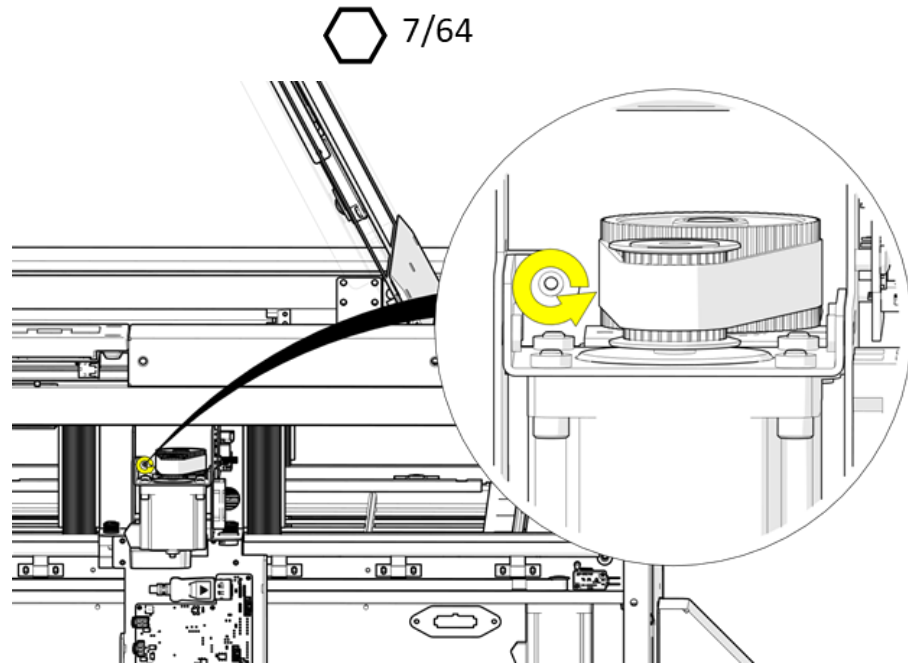

12. Move:

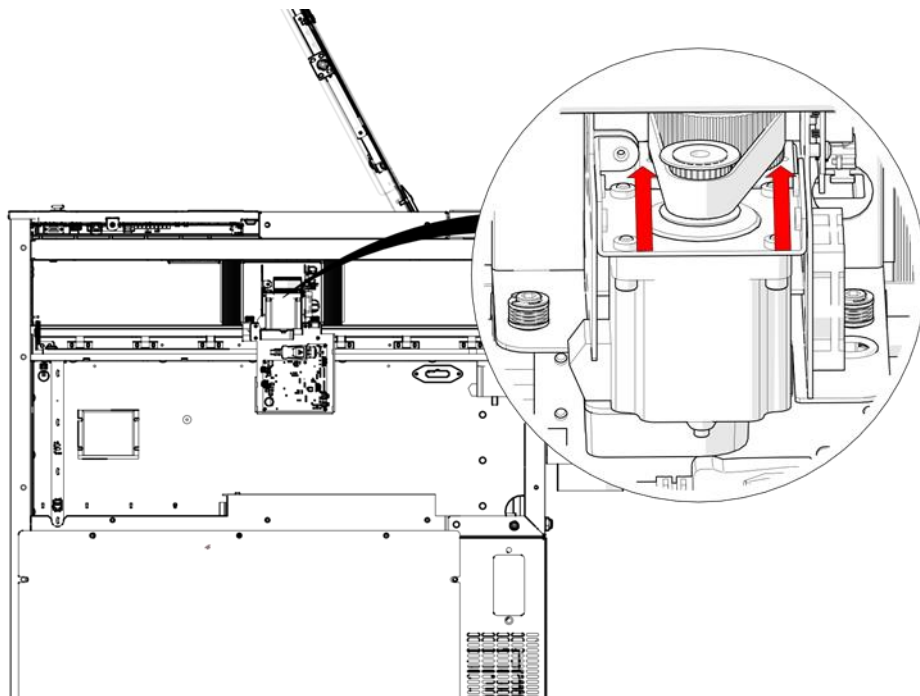

13. Remove:

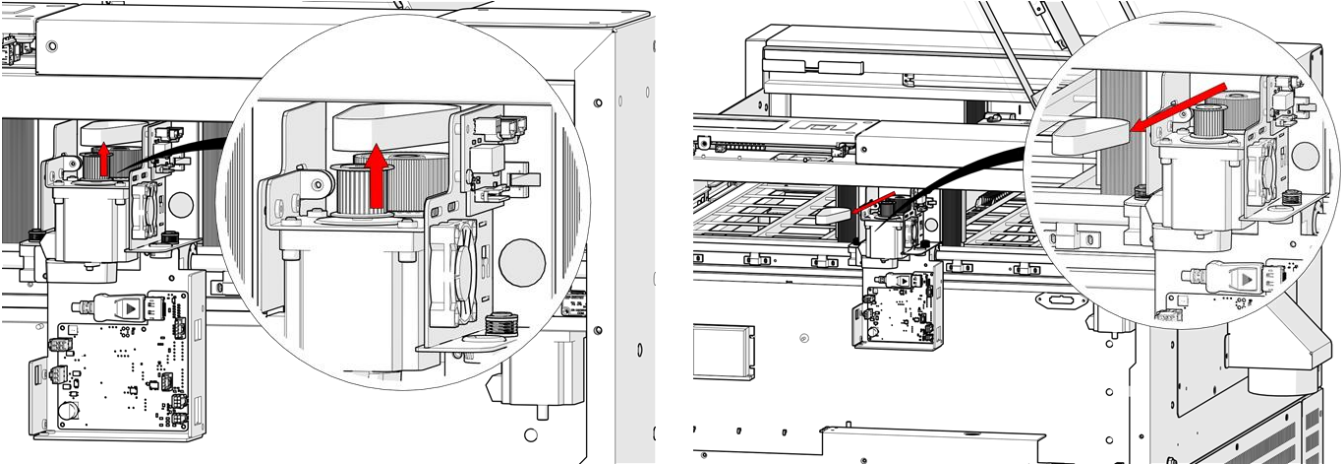

14. Remove:

7/64

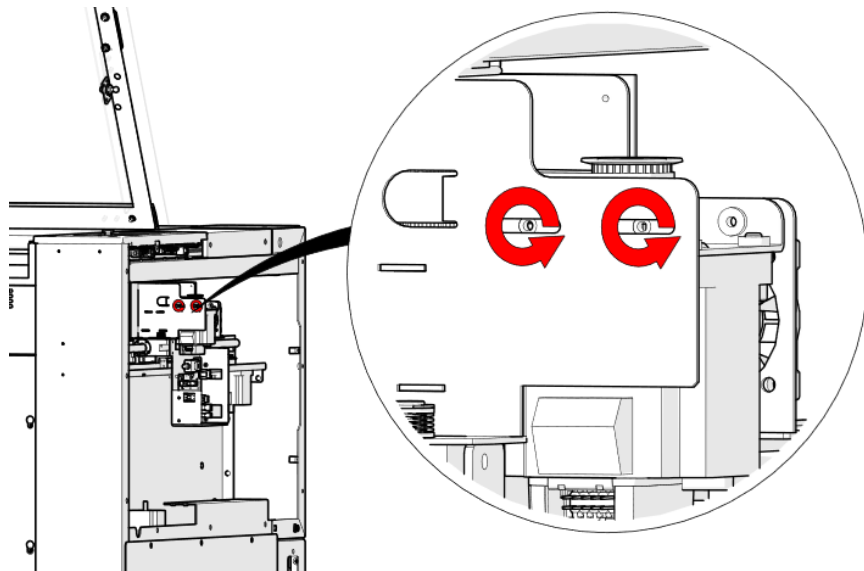



15. Remove:

⬡ 7/64

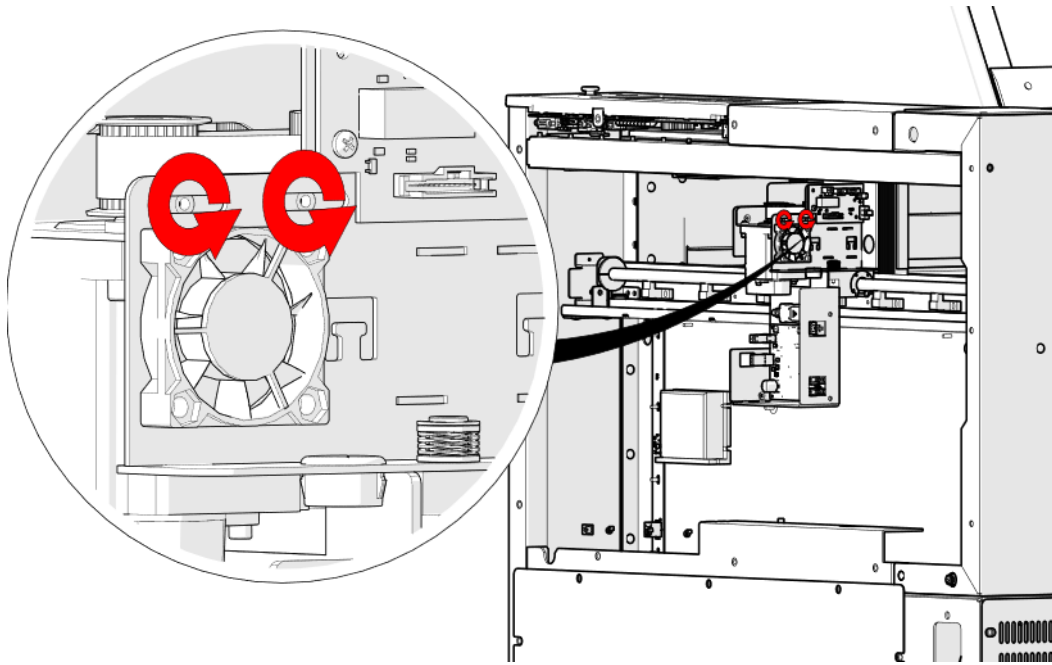

16. Remove:

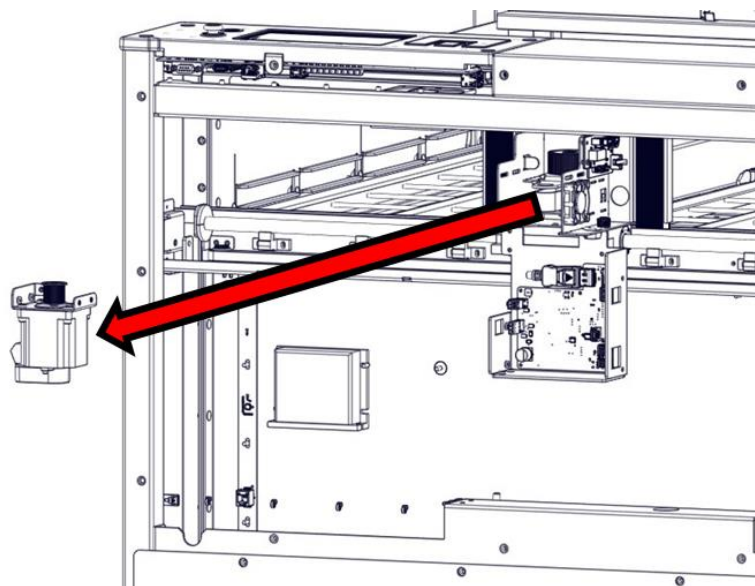

17. Install:

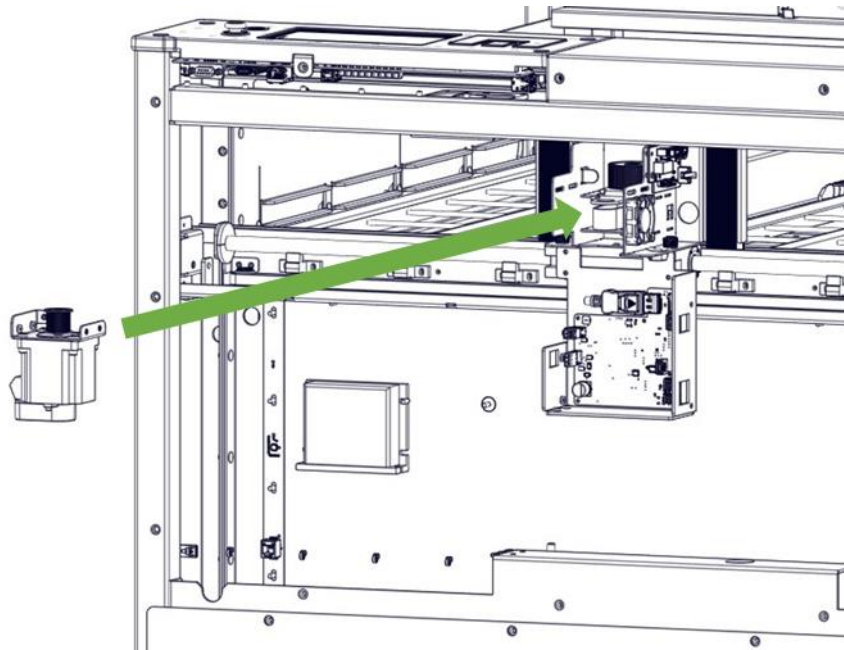

18. Install, do not tighten:

⬡ 7/64

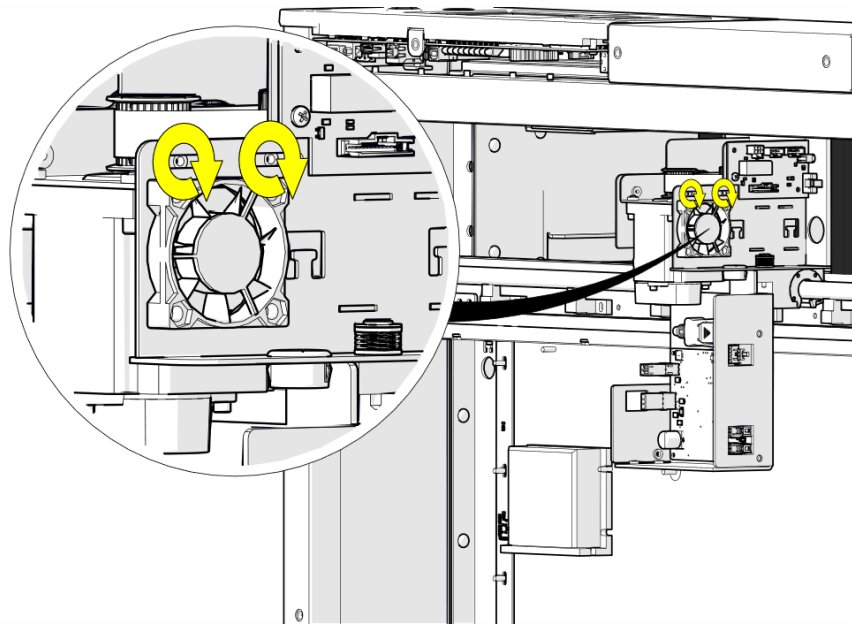

19. Install, do not tighten:

 7/64

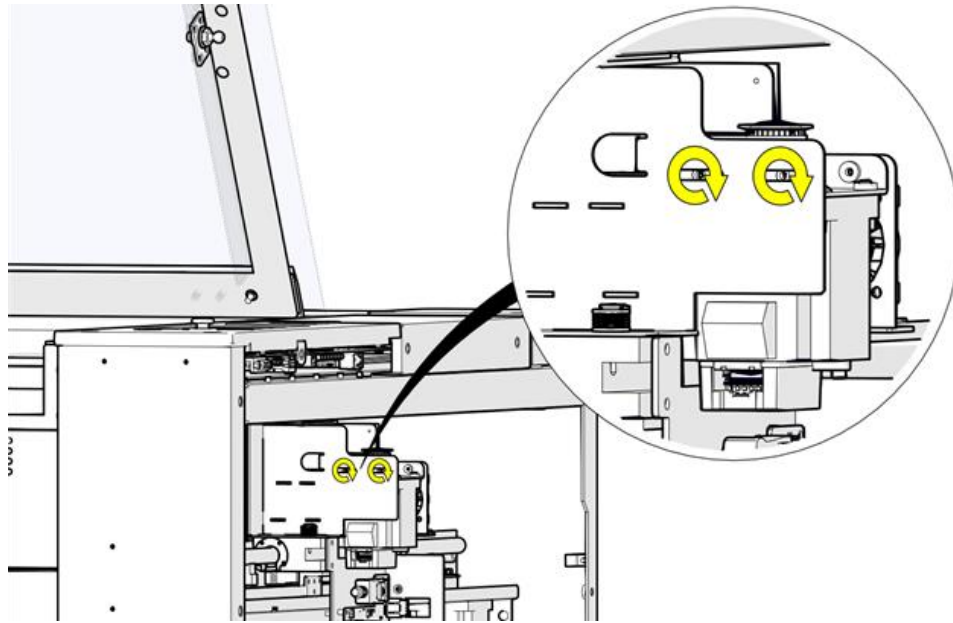

20. Install

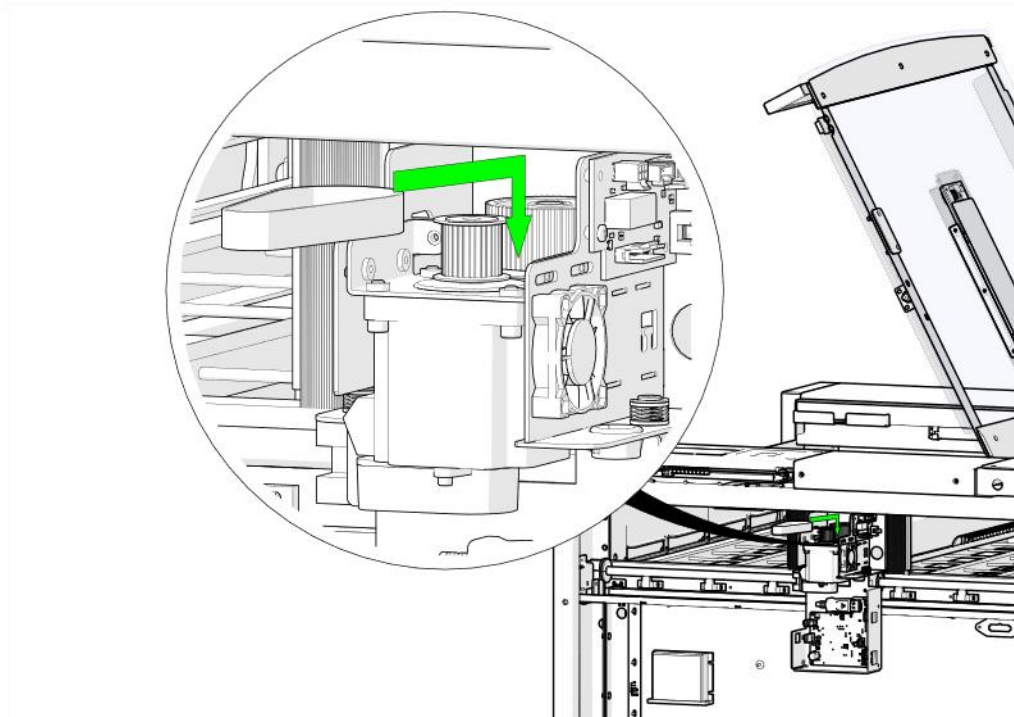

21. Tighten:

⬡ 7/64

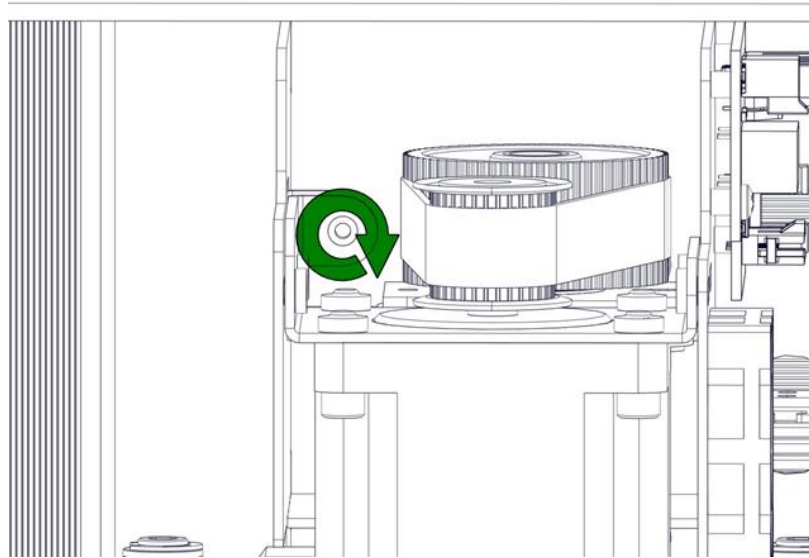

22. Tighten:

⬡ 7/64

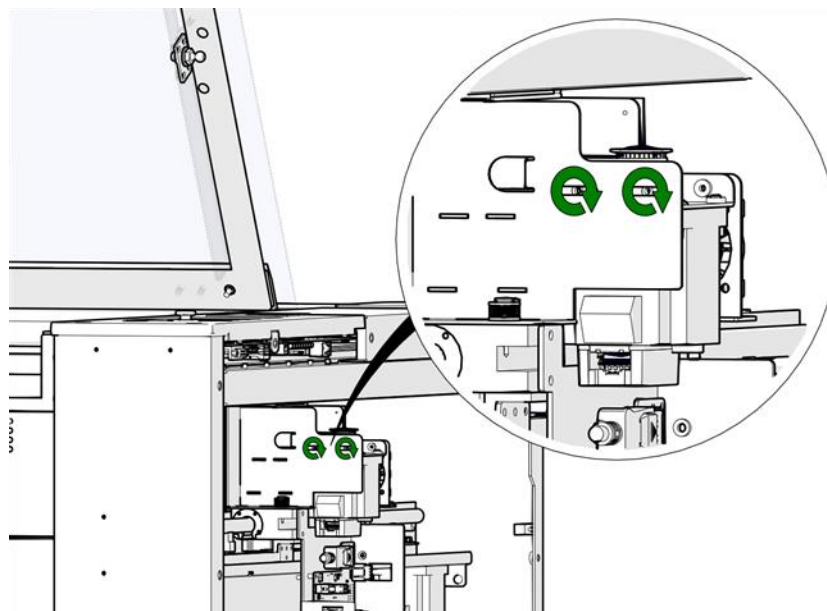

23. Tighten:

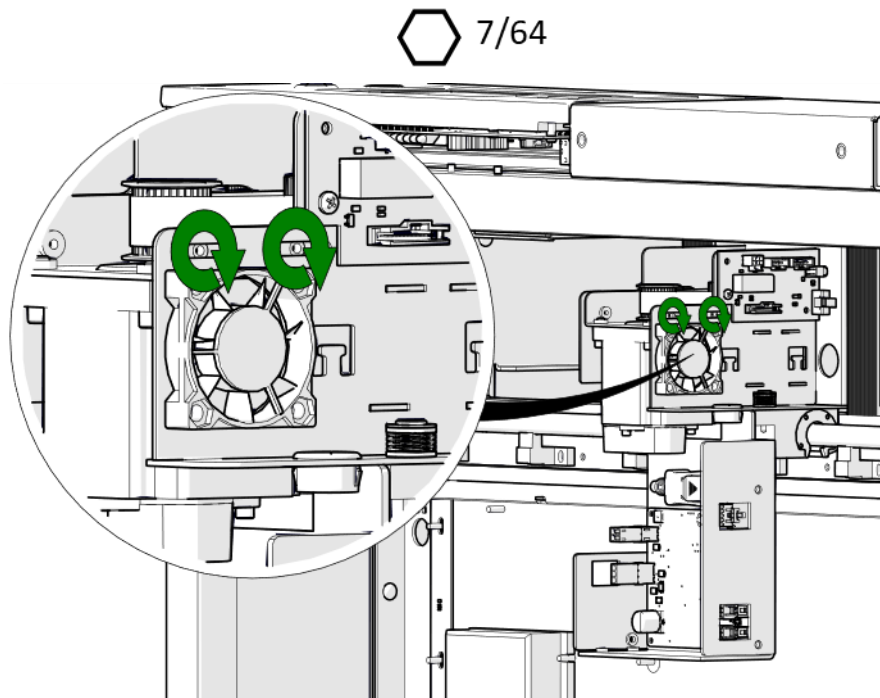

24. Reconnect:

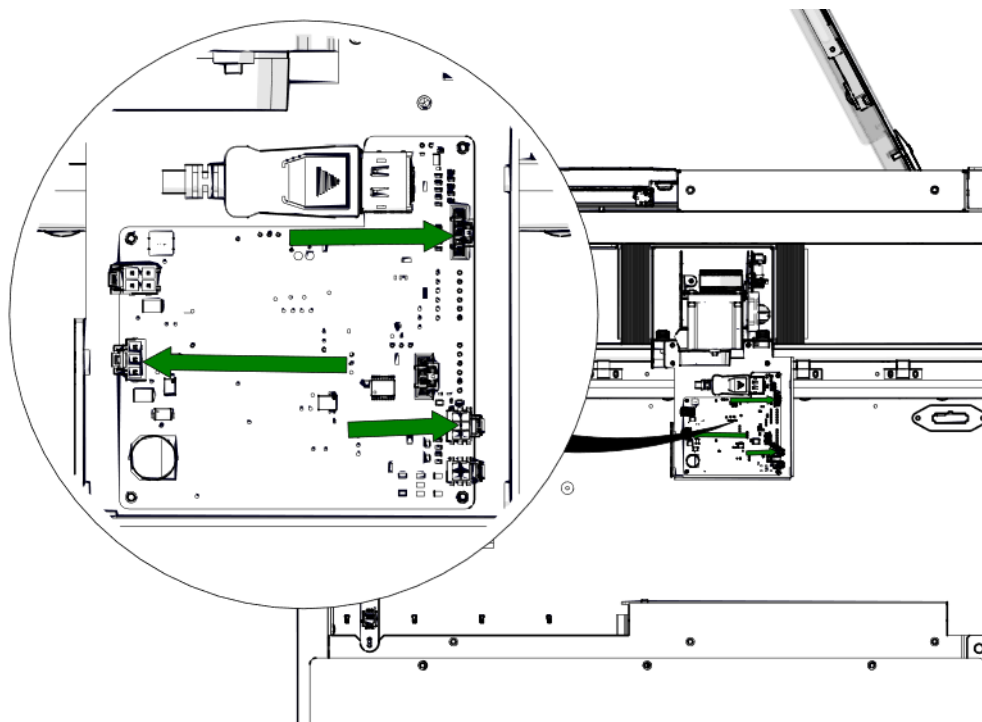

25. Install:

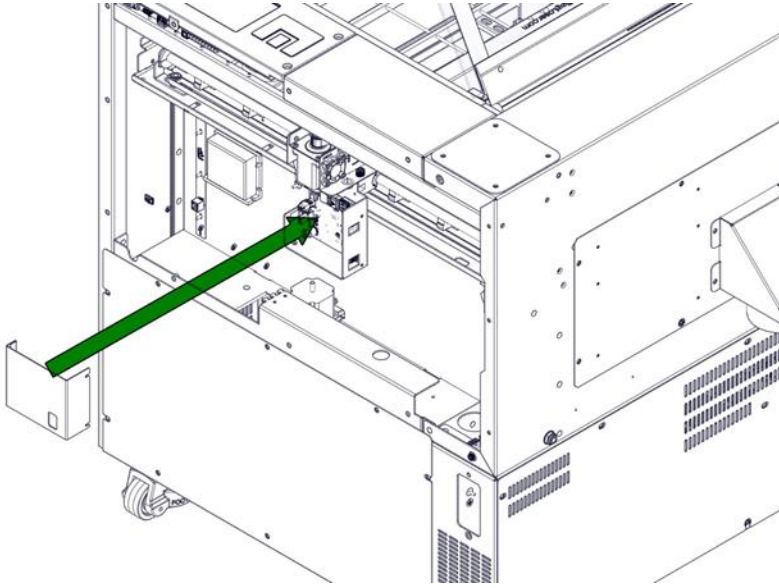

26. Tighten:

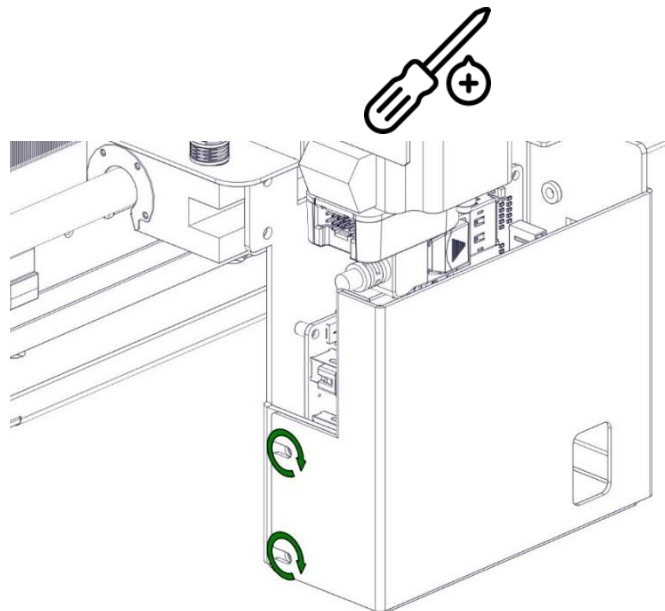

# Edge/Edge Pro X-Axis Motor

Tighten:

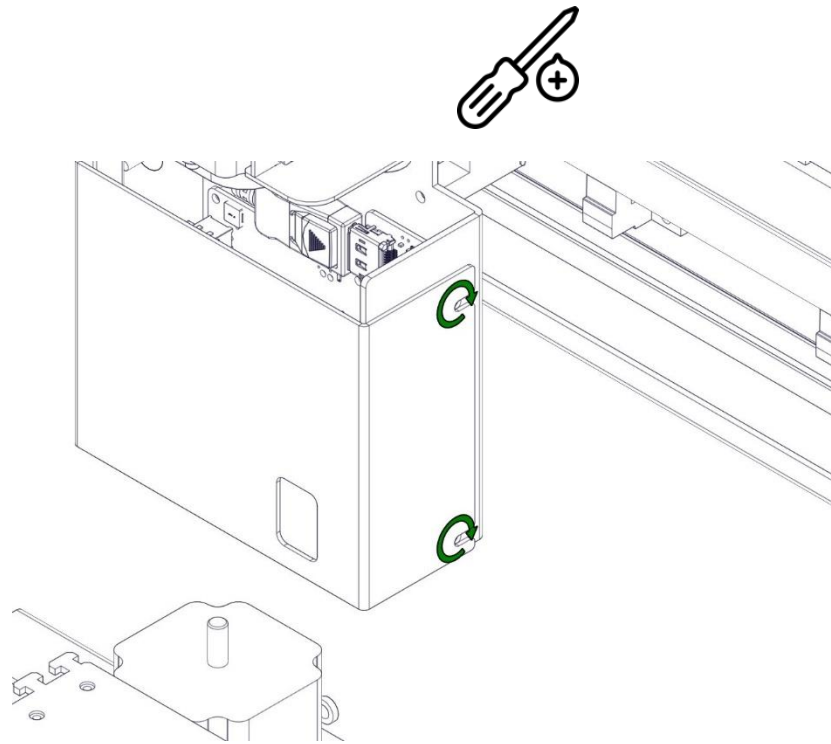

27. Replace:

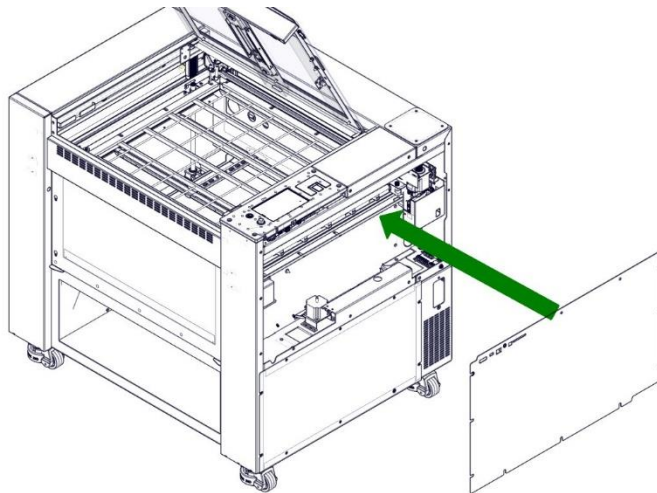
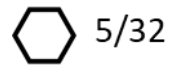

28. Reconnect:



Connect Power

29. Start machine





### Belt Tension Procedure

Test "TTTTTTTT" Times New Roman.

TTTTTT ✓ Done!

TTTTTT ✗ Continue

30. Loosen

7/64

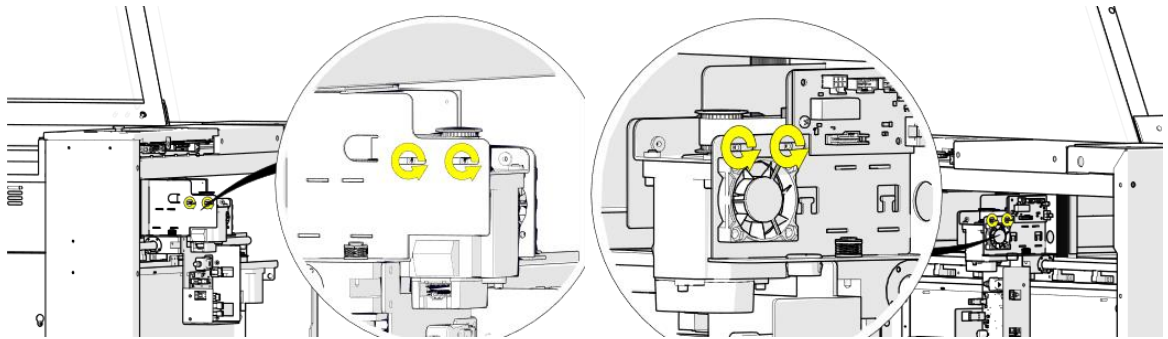

31. Tighten or Loosen

7/64

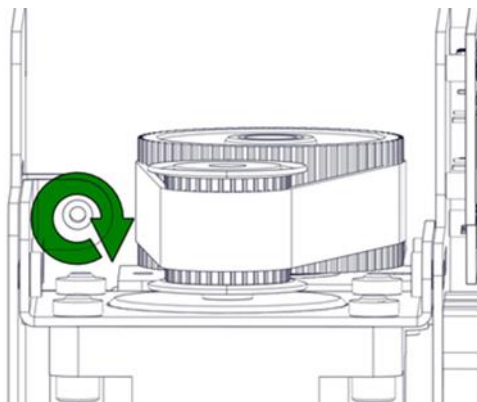

32. Tighten:

 7/64

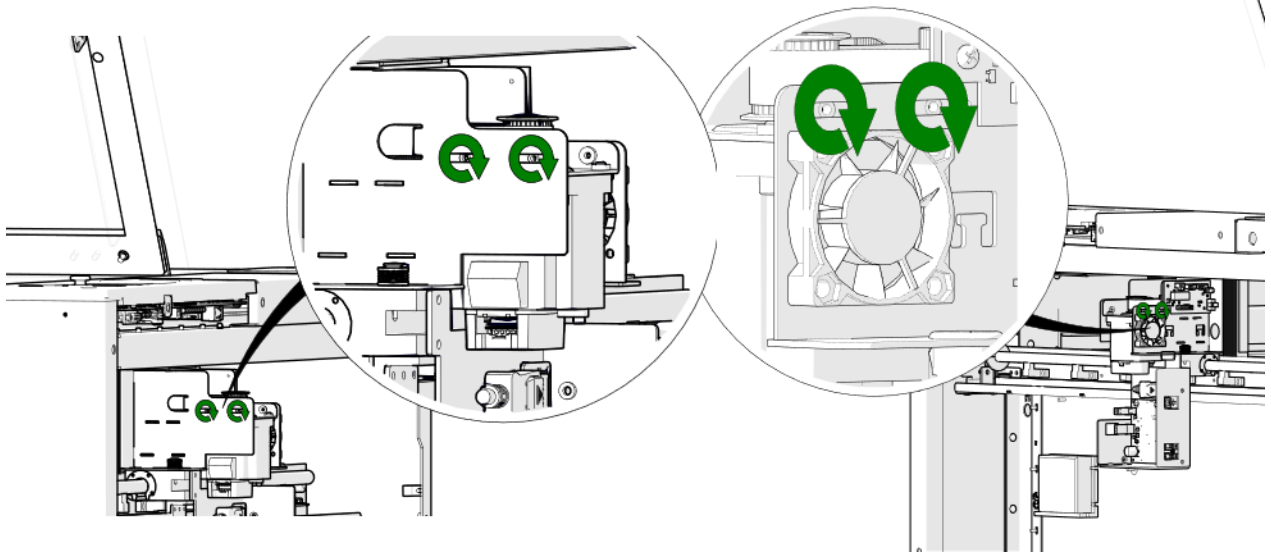

33. Test and adjust Until:

**TTTTT**  Done